

Log Forks

Do you need a heavy duty log fork that features improved visibility and reliability?

Then upgrade now to the latest TRINDER log fork! It's the best in the business

- Easy Access Grease Points
- Fully Guarded Commercially Manufactured Hydraulic Rams
- Mounts specifically designed and manufactured to suit your machine

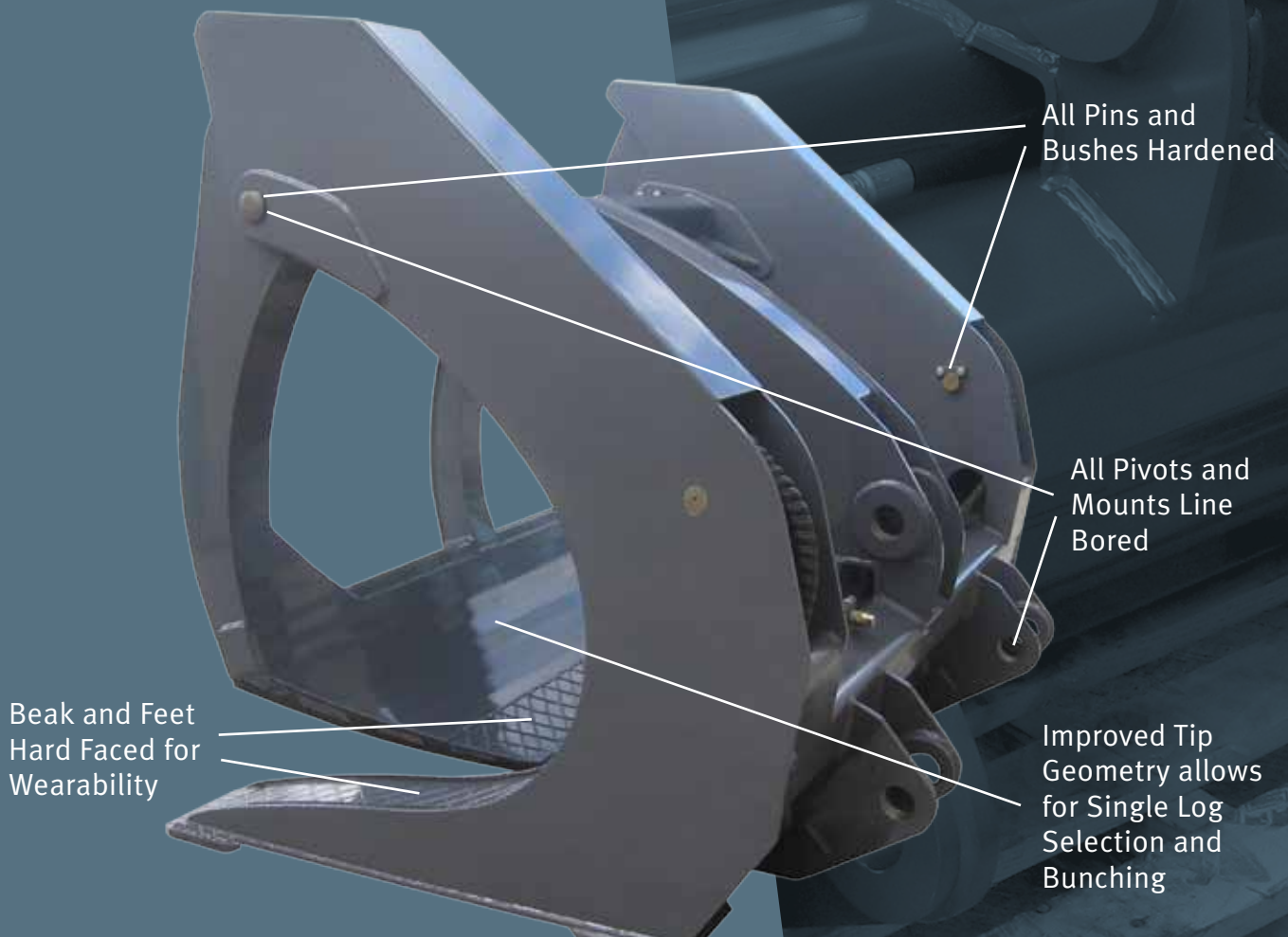

- Designed to withstand above average abuse
- Single log selection or bunching

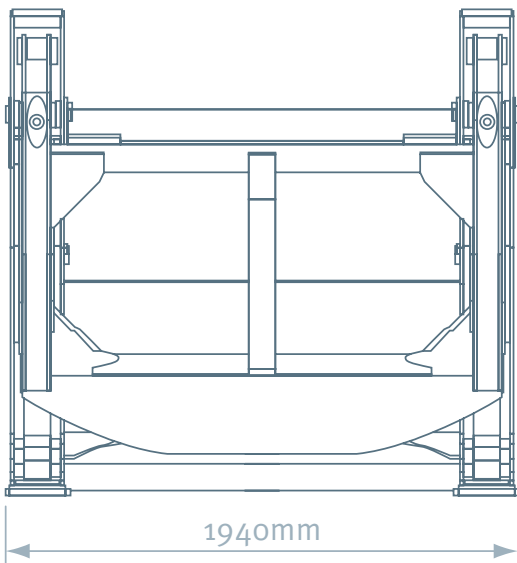
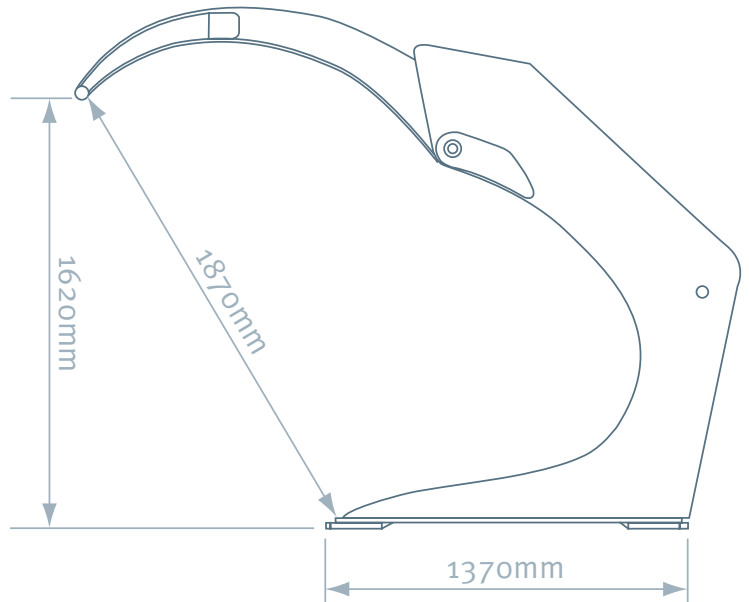
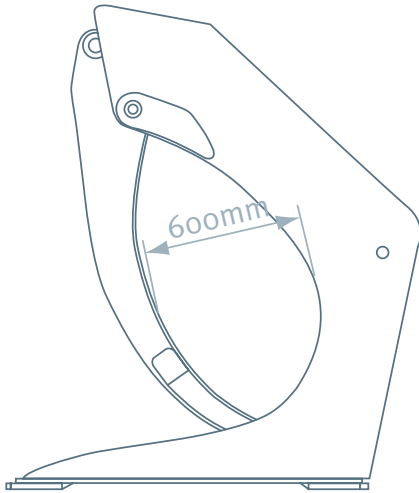

Contact – Trinder Engineers

Andrew Brough
 Structural & Manufacturing Manager
 Phone: (03) 544 8024 ext. 325
 Fax: (03) 544 8023
 Mobile: 027 681 7466
 aj@trinder.co.nz
 PO Box 3143, Gladstone Road, Richmond, Nelson, New Zealand

www.trinder.co.nz

Contact – Devine Engineering

Bernie Money
 Phone: (07) 378 5540
 Fax: (07) 378 6542
 Mobile: 0274 800 866
 144 Rakaunui Road, Taupo, New Zealand

www.devine2006.co.nz

